

**Q150Z
Q170Z / Q180 HPLS
Q130ZD**

LIFETIME EXCELLENCE

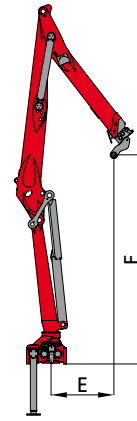

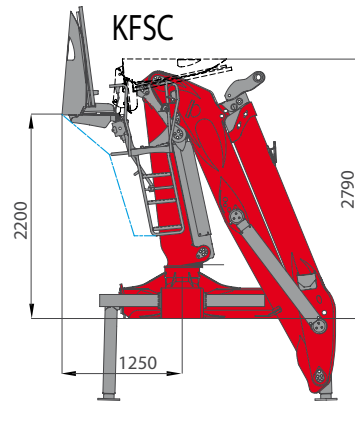
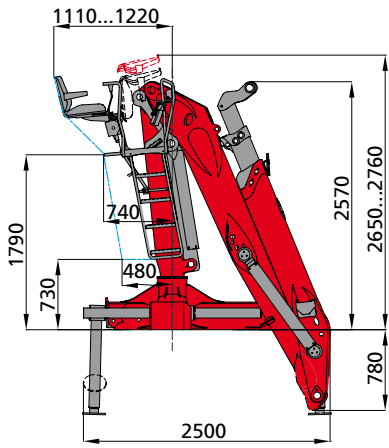
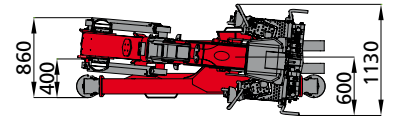
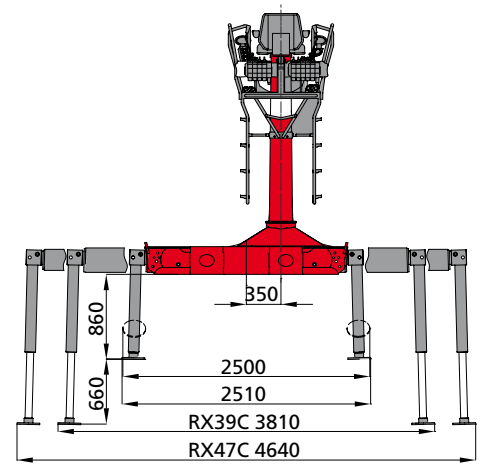
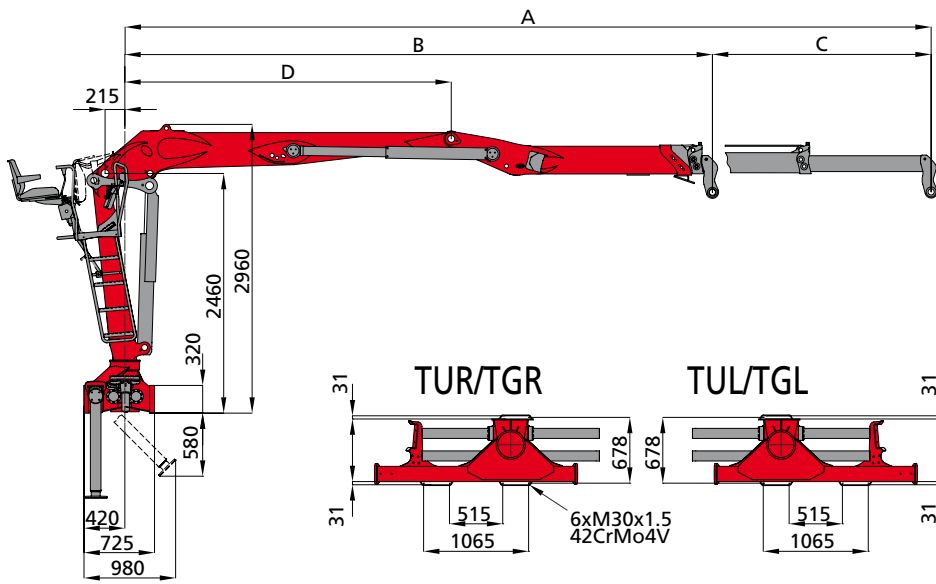

	82	79	96
A	8220	7900	9600
B	5980	6320	6440
C	2240	1580	3160
D	3285	3285	3285
E	1090	1300	1360
F	3530	3270	3170

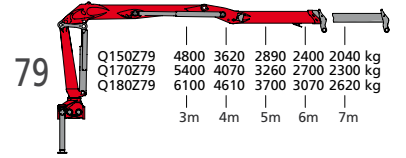
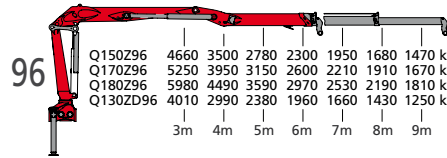
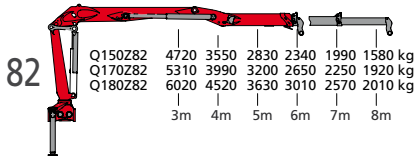

		Q150Z			Q170Z			Q180Z ^{HPLS}			Q130ZD	
		82	79	96	82	79	96	82	79	96	96	
ONROAD RECYCLING												
	[kNm]	142	145	140	160	163	158	181	185	180	120	
	[kNm]	30			32			32			30	
	[°]	425										
	[m]	8,2	7,9	9,6	8,2	7,9	9,6	8,2	7,9	9,6	9,6	
	[bar]	235			260			260 (290 HPLS)			210	
	1K [l/min]						1 x 90					-
	2K [l/min]						2 x 80					2 x 80
	1K LS [l/min]						1 x 150					1 x 150
	[kg]	2600	2550	2680	2640	2590	2720	2650	2600	2730	2720	
	RX39C [kN]	118			130			145			113	
	RX47C [kN]	96			106			118			91	